



ARIETE

NS3006Energy

The Ariete Energy Series high pressure homogeniser/pump features the latest in design concept, contributing to excellence in performance and reliability.

Liquid end

- High quality stainless steel and special high wear resistance materials for best mechanical and corrosion resistance performances
- 3A and electropolished versions available
- Ball (PVB) and poppet valves (PVP) interchangeable into the same block design for maximum product handling flexibility
- Aseptic version compression block available with sterile condensate packing flushing
- Various materials for pumping plungers

Homogenising valve

- One stage (standard on homogenizers) with hand wheel adjustment
- High efficiency design homogenizing valve, based on advanced fluid dynamics concepts
- Engineered for easy maintenance and cleaning
- Second stage option

Power end

- Heavy duty and reliable power frame
- AC motor drive
- Splash type lubrication system
- "V" belts direct drive

Casing

- Polished stainless steel with removable panels for easy access and maintenance
- Galvanized steel base frame on adjustable legs

Tools and spares parts

- Special tools and one set of emergency spares parts supplied with the machine
- O&M manual and Spare parts list on CD-ROM

ARIETE

NS3006Energy



- Designed according to the EU safety rules (CE standards), engineered, manufactured and tested according to ISO EN 9001 Quality System
- Sanitary and aseptic execution, designed for CIP and SIP
- Suitable for abrasive and viscous products
- Homogenizing pressure up to 1500 bar
- Monoblock compression head design up to 600 bar pressure
- Multi block VHP compression head design for operation over 600 bar, to avoid stress concentration and block failure
- Easy implementation in remote control systems and complete process lines

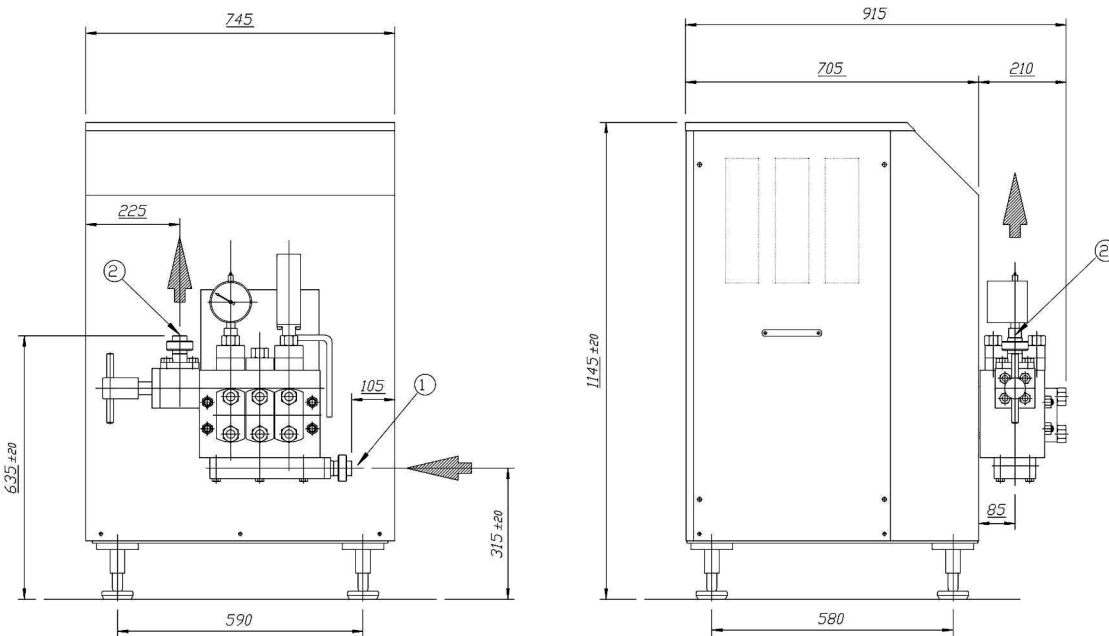

*measure in mm

Performances

	150 bar	180 bar	200 bar	250 bar	400 bar	600 bar	1000 bar	1200 bar	1500 bar
Max Flow Rate (l/h)	1000	750	750	600	350	220	120	120	50

Design Features and Materials

- Compression head — special high grade duplex / super-duplex SS alloy
- MONOBLOCK or Multi-Block VHP construction
- Pump Valves — high wear resistant Stellite® alloy removable seats
- ball type (PVB) or poppet type (PVP) in solid Stellite®
- Pistons — Chrome coated stainless steel
- Tungsten carbide coated stainless steel
- Solid ceramic
- Homogenizing Valve — Handwheel actuated
- wear parts made of Tungsten Carbide or Ceramics
- Pressure Gauge — sanitary design analog high pressure gauge
- Product line connections — DIN 11851, Tri-Clamp®
- others as option upon request
- Power end — rugged cast iron power frame
- splash lubrication, forced as option
- polished SS machine casing on galvanized steel frame
- Main options — high pressure pump version
- 2nd stage homogenizing valve
- electric power board for fixed or variable capacity

Technical Data

Number of plungers	3
Stroke.....	40-50 mm
Max motor power	5,5 kW
Weight	550 kg
Water consumption.....	60 lph
Lubricating oil ISO VG 150.....	3 l

* technical specifications are not mandatory and subject to change without notice