

TWINPANDA 600 NS2002H



Niro Soavi presents the TwinPanda 600 laboratory/pilot homogenizer. It is capable of handling feeds with a range of viscosities at pressures of up to 600 bar g.

With a small hold up volume and a flow rate of 30 l/h it is ideal for pilot process testing in food, dairy and chemical Industries.

Compression Block

- Manufactured in high grade and high performances duplex stainless steel, the compression block is designed to ensure the maximum stress resistance to maximise the performances and reliability at high operating pressure
- Solid ceramic pumping plungers equipped with specially designed packings to avoid the need of lubrication water
- Suction and delivery ball valves (PVB) in Stellite®, with replaceable suction valve seat in Stellite®
- Analog pressure gauge, with built-in pulsation damper, with optional pressure transmitter (4-20 mA signal)

Homogenizing Valve

- Wear parts in tungsten carbide, fully reversible
- Manual pressure adjustment by means of a hand-wheel
- Second stage homogenizing valve group applied as standard
- Allow front/side/upwards outlet to match with plant piping layout

Product Inlet/Outlet

- Tri-Clamp® connections for inline installation
- No feeding pump is needed (for product viscosity up to 1000 cP)

Power End

- Maintenance - free timing belt drive
- Three phase motor , suitable for Variable Speed Drive
- Camshaft drive system and maintenance-free grease lubrication

Casing

- Panels made in polished stainless steel, completely removable for maintenance and cleaning
- High quality paint steel base frame
- Adjustable anti-vibration rubber feet

TWINPANDA 600

NS2002H



- The TwinPanda 600 is a small table-top laboratory/pilot unit designed for continuous operation up to 600 bar, suitable for microsizing tests on many different fluids and pilot scale process trials.
- The TwinPanda 600's flexibility makes it a useful tool for many different sectors, such as the food, dairy, chemical industries.

Main Features:

- Compact design for easy installation, use and maintenance
- Suitable for viscous pumpable products, up to 1000 cP without feeding pump
- SS feeding hopper (2,5 l) supplied as standard
- 3A version available as option
- FDA approved gaskets, available as option
- Suitable for CIP/SIP
- Suitable for in-line installation, with Tri-Clamp® connections to a feeding and a discharge tank
- Three-phase electricity is the only utility needed, the machine is supplied with in-built motor starter
- No need for cooling/lubrication water
- Aseptic version available as option
- Suitable for variable Speed Drive

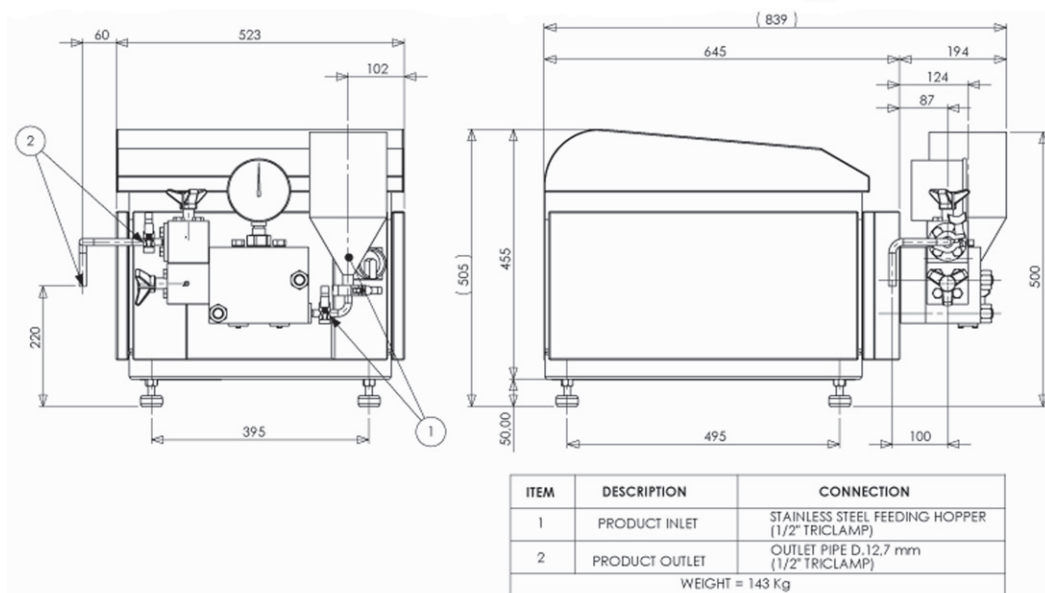

*dimension in millimeters

Design Features and Performances

- Max operating pressure 600 bar
- Flow rate of 30 l/h @ 600 bar
- Minimum sample volume approx 500 ml
- Three-phase motor 1,5 kW @ 400V / 50 Hz
- Weight 143 Kg
- Dimensions mm
- Connections in/out 1/2" Tri-Clamp®

* technical specifications are not mandatory and subject to change without notice